



www.rpesrl.com

RPE V4

the media-separated valve that has it all



LEADER IN FLUID MANAGEMENT CONTROL



Media-separated

Universal media compatibility:

Coffee

Tea

Milk

Water

Cleaning
agents

Aggressive
products





Media-separated

Interlinkable

Connect
all
the valves
you need

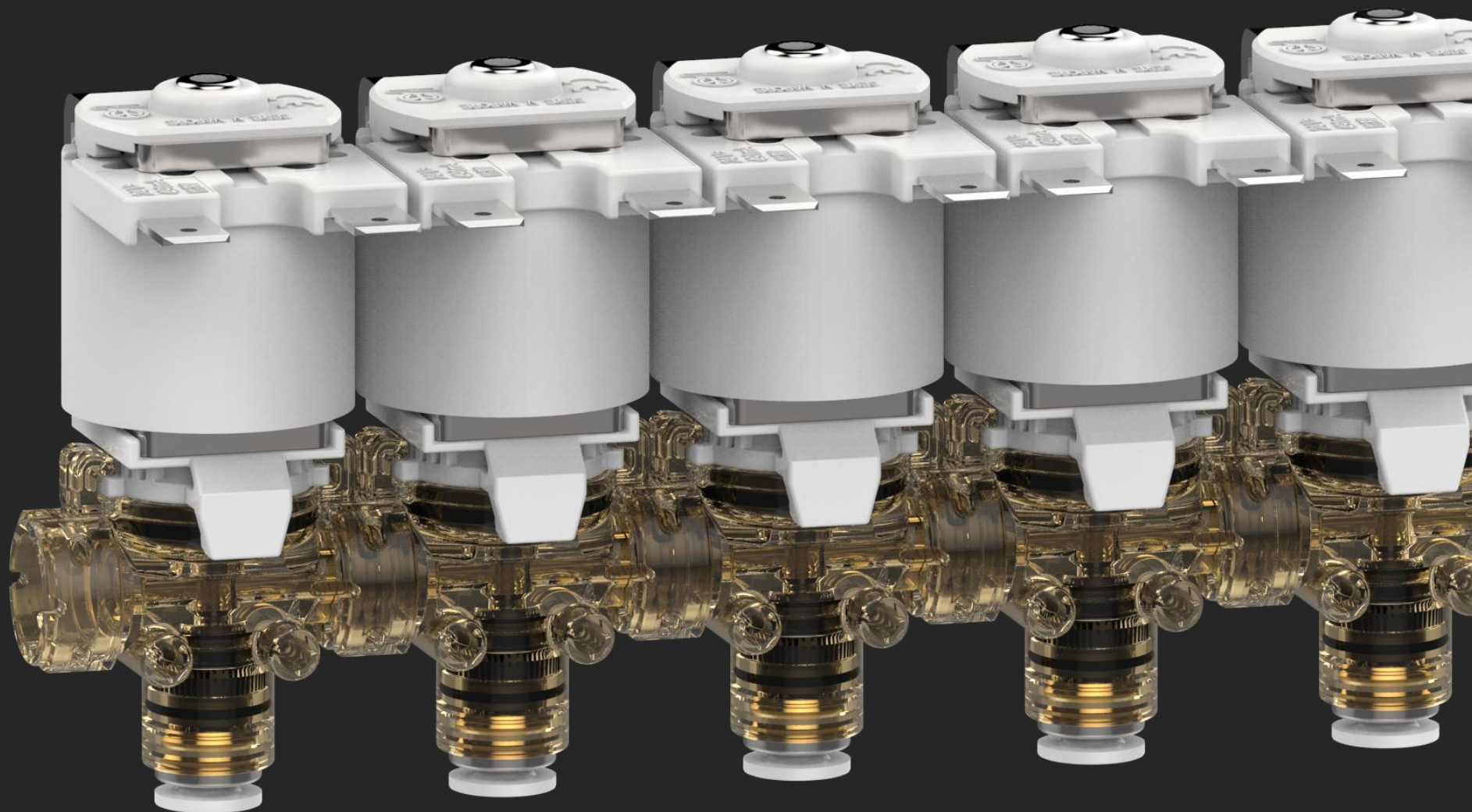



Media-separated

Interlinkable

Powerful

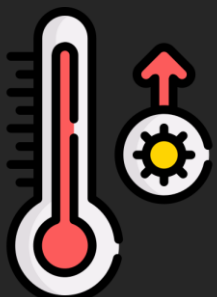

Withstands temperatures:
1-140°C



High operating pressure up to
15
bar





Media-separated

Interlinkable

Powerful

Self-cleaning

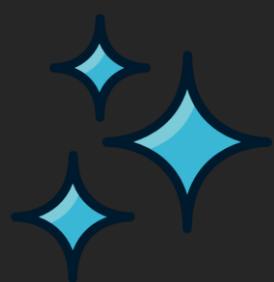

Self-cleaning system

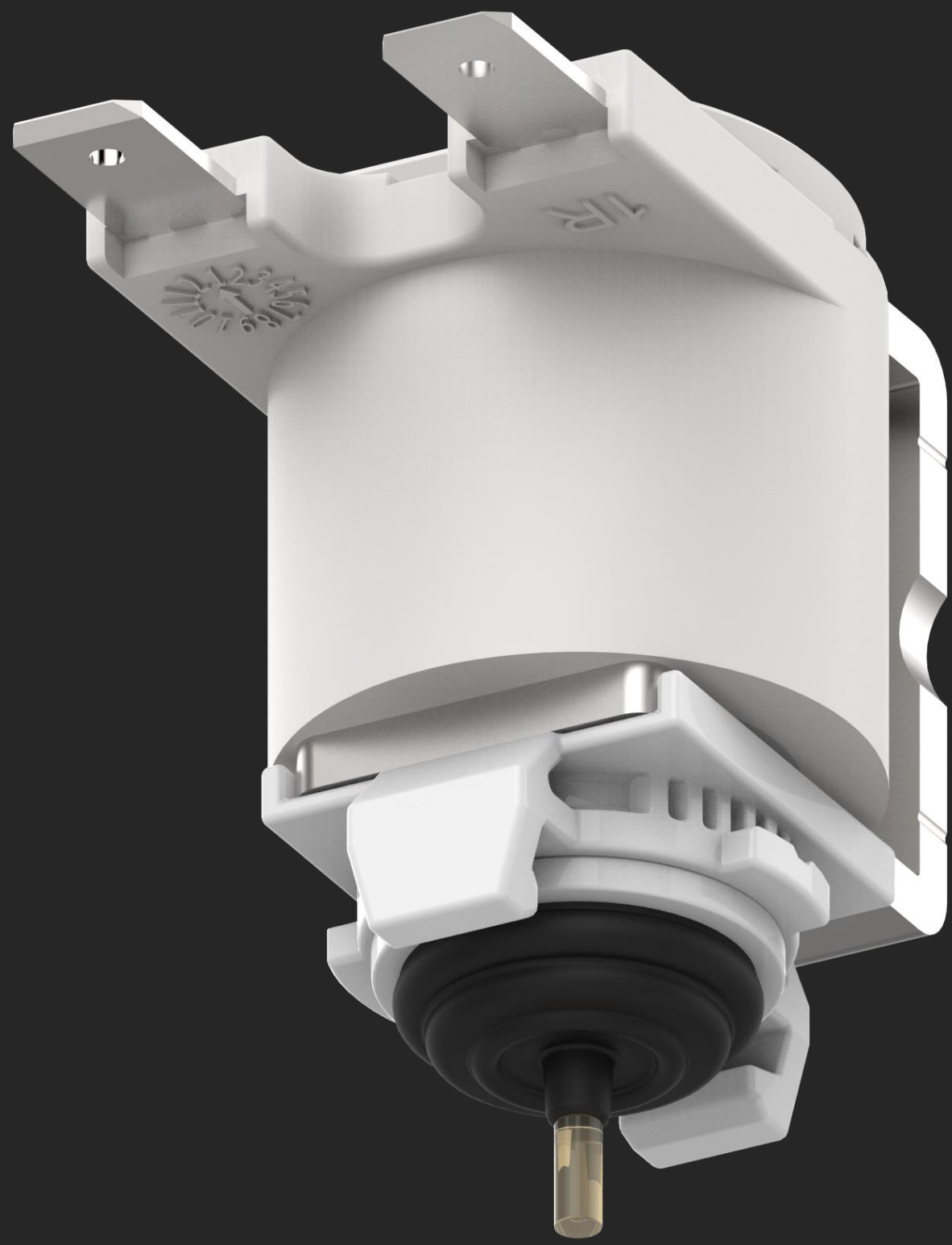



Media-separated

Interlinkable

Powerful

Self-cleaning

Durable

Long-lasting
PPSU polymer



Limescale
& corrosion
resistant



Reduced service
& maintenance
frequency

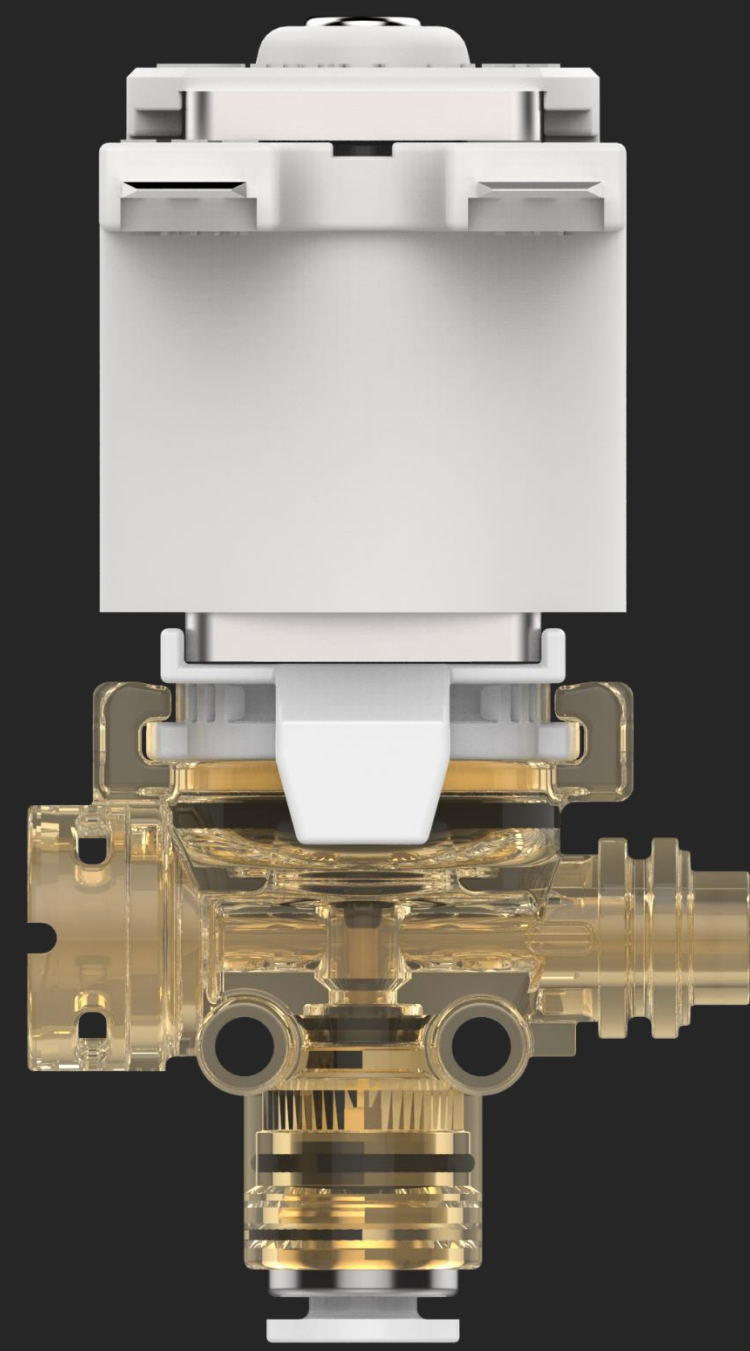



Media-separated

Interlinkable

Powerful

Self-cleaning

Durable

Compact



*further details in technical datasheet



**“NOTHING GREAT HAS EVER BEEN
DONE WITHOUT PASSION”**

G.W.F.Hegel